

LM25007

42V, 0.5A Step-Down Switching Regulator

General Description

The LM25007 is a monolithic step-down switching regulator featuring all of the functions needed to implement a low cost, efficient, power supply. Capable of driving a 0.5Amp load over a 9V-42V input voltage range, this device is easy to apply and is provided in the small MSOP-8 and the thermally enhanced LLP-8 packages. Ultra-fast transient response is achieved through the use of a constant on-time architecture with V_{in} feed forward. This feature provides an almost constant operating frequency over load and input voltage variations. The operating frequency can be adjusted with a single resistor. This architecture is easy to use and tolerant of component selection. An intelligent current limit is implemented in the LM25007 with forced off time that is inversely proportional to V_{out} thus ensuring recovery from fault conditions. The output voltage may be set from 2.5V to >30V. To improve efficiency in light load applications, the V_{cc} pin can be connected to an external voltage source to eliminate the drop through the internal regulator. Additional features include: thermal shutdown, V_{cc} under-voltage lockout, gate drive under-voltage lockout, and max duty cycle limiter.

Features

- Integrated 0.74 ohm N-Channel MOSFET switch
- Guaranteed 0.5Amp output current
- Ultra-Fast Transient Response
- Up to 800kHz operation
- No control loop compensation required
- V_{in} feed forward provides constant operating frequency
- 2% accurate 2.5V feedback from -40°C to 125°C
- Highly efficient operation
- Intelligent current limit protection
- External shutdown control
- Thermal shutdown
- MSOP-8 and thermally enhanced LLP packages

Typical Applications

- 12VDC and 24VDC distributed rail systems
- 24VAC systems
- Automotive body electronics and telematics
- Industrial systems
- HB-LED constant current source

Package

- MSOP - 8
- LLP - 8 (4mm x 4mm)

Basic Step-Down Regulator

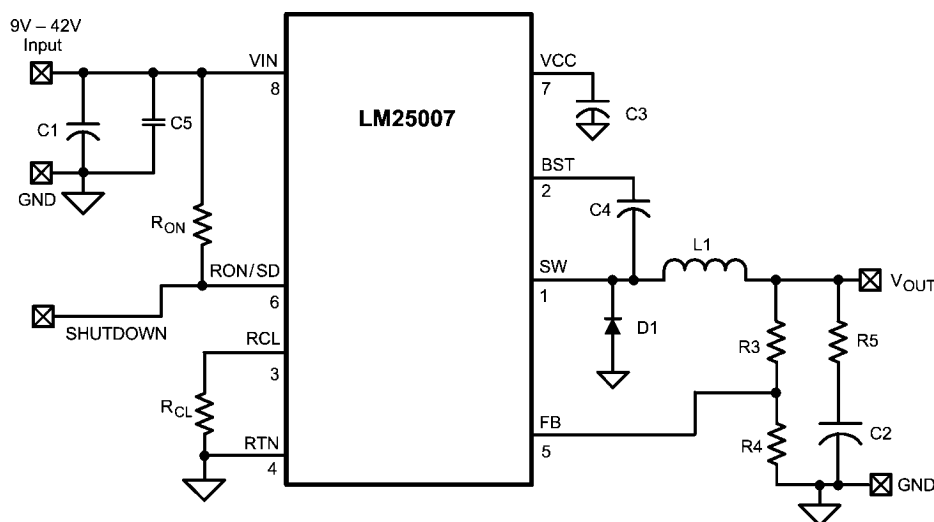

20165513

Connection Diagram

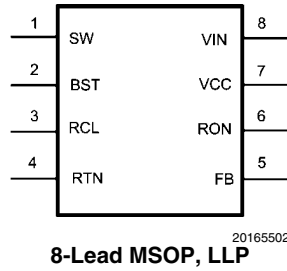

Ordering Information

Order Number	Package Type	NSC Package Drawing	Supplied As
LM25007MM	MSOP-8	MUA08A	1000 Units on Tape and Reel
LM25007MMX	MSOP-8	MUA08A	3500 Units on Tape and Reel
LM25007SD	LLP-8	SDC08A	1000 Units on Tape and Reel
LM25007SDX	LLP-8	SDC08A	4500 Units on Tape and Reel

Pin Descriptions

Pin	Name	Description	Application Information
1	SW	Switching Node	Power switching node. Connect to the inductor, bootstrap capacitor, and free-wheeling diode.
2	BST	Boost Boot-strap capacitor input	An external capacitor is required between the BST and the SW pins. A 0.01 μ F ceramic capacitor is recommended.
3	RCL	Current Limit OFF time programming pin	A resistor between this pin and RTN sets the off-time when current limit is detected. The off-time is preset to 17 μ s if FB = 0V .
4	RTN	Circuit Ground	
5	FB	Feedback Signal from Regulated Output	This pin is connected to the inverting input of the internal regulation comparator. The regulation threshold is 2.5V.
6	RON/SD	On-time set pin	A resistor between this pin and VIN sets the switch on-time as a function of Vin. The minimum recommended on-time is 300ns at the maximum input voltage.
7	VCC	Output from the internal high voltage bias regulator.	If an auxiliary voltage is available to raise the voltage on this pin above the regulation setpoint (7V), the internal series pass regulator will shutdown, reducing the IC power dissipation. Do not exceed 14V. This output provides gate drive power for the internal Buck switch. An internal diode is provided between this pin and the BST pin. A local 0.1 μ F decoupling capacitor is recommended.
8	VIN	Input supply voltage	Recommended operating range: 9V to 42V.
-	EP	Exposed pad, underside of the LLP package option	Exposed metal pad on the LLP package underside. It is recommended to connect this pad to the PC board ground plane to aid in heat dissipation.

Typical Application Circuit and Block Diagram

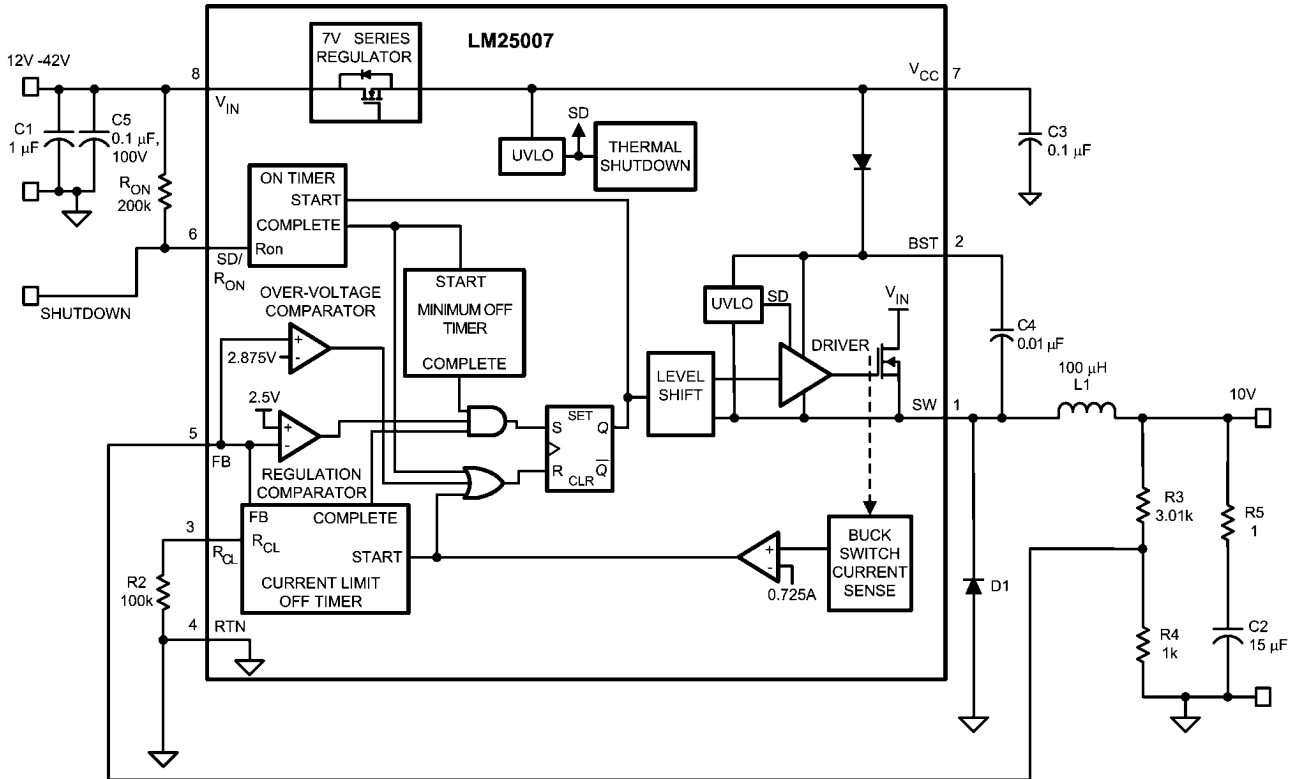

20165501

Absolute Maximum Ratings (Note 1)

If Military/Aerospace specified devices are required, please contact the National Semiconductor Sales Office/Distributors for availability and specifications.

VIN to RTN	45V
BST to RTN	59V
SW to RTN (Steady State)	-1V
ESD Rating (Note 5)	
Human Body Model	2kV

BST to V _{CC}	45V
BST to SW	14V
VCC to RTN	14V
All Other Inputs to RTN	-0.3 to 7V
Storage Temperature Range	-65°C to +150°C

Operating Ratings (Note 1)

V _{IN}	9V to 42V
Junction Temperature	-40°C to + 125°C

Electrical Characteristics

Specifications with standard type are for T_J = 25°C only; limits in boldface type apply over the full Operating Junction Temperature (T_J) range. Minimum and Maximum limits are guaranteed through test, design, or statistical correlation. Typical values represent the most likely parametric norm at T_J = 25°C, and are provided for reference purposes only. Unless otherwise stated the following conditions apply: V_{IN} = 24V, R_{ON} = 200kΩ. (Note 3).

Symbol	Parameter	Conditions	Min	Typ	Max	Units
Startup Regulator						
V _{CC} Reg	V _{CC} Regulator Output		6.6	7	7.4	V
	V _{CC} Current Limit	(Note 4)		11		mA
V_{CC} Supply						
	V _{CC} undervoltage Lockout Voltage (V _{CC} increasing)			6.3		V
	V _{CC} Undervoltage Hysteresis			206		mV
	V _{CC} UVLO Delay (filter)			3		μs
	Operating Current (I _{CC})	Non-Switching, FB = 3V		500	675	μA
	Shutdown/Standby Current	RON/SD = 0V		70	150	μA
Switch Characteristics						
	Buck Switch Rds(on)	I _{TEST} = 200mA, VBST - VSW = 6.3V (Note 6)		0.74	1.34	Ω
	Gate Drive UVLO (VBST - VSW)	Rising	3.4	4.5	5.5	V
	Gate Drive UVLO Hysteresis			400		mV
Current Limit						
	Current Limit Threshold		535	725	900	mA
	Current Limit Response Time	I _{switch} Overdrive = 0.1A Time to Switch Off		225		ns
	OFF time generator (test 1)	FB=0V, RCL = 100K		17		μs
	OFF time generator (test 2)	FB=2.3V, RCL = 100K		2.65		μs
On Time Generator						
	TON -1	Vin = 10V Ron = 200K	2.15	2.77	3.5	μs
	TON -2	Vin = 40V Ron = 200K	450	615	810	ns
	Remote Shutdown Threshold	Rising	0.45	0.7	1.1	V
	Remote Shutdown Hysteresis			40		mV

Symbol	Parameter	Conditions	Min	Typ	Max	Units
Minimum Off Time						
	Minimum Off Timer	FB = 0V		300		ns
Regulation and OV Comparators						
	FB Reference Threshold	Internal reference Trip point for switch ON	2.445	2.5	2.550	V
	FB Over-Voltage Threshold	Trip point for switch OFF		2.875		V
	FB Bias Current			100		nA
Thermal Shutdown						
Tsd	Thermal Shutdown Temp.			165		°C
	Thermal Shutdown Hysteresis			25		°C
Thermal Resistance						
θ_{JA}	Junction to Ambient	MUA Package		200		°C/W
		SDC Package		40		°C/W

Note 1: Absolute Maximum Ratings are limits beyond which damage to the device may occur. Operating Ratings are conditions under which operation of the device is intended to be functional. For guaranteed specifications and test conditions, see the Electrical Characteristics.

Note 2: For detailed information on soldering plastic MSOP and LLP packages, refer to the Packaging Data Book available from National Semiconductor Corporation.

Note 3: All limits are guaranteed. All electrical characteristics having room temperature limits are tested during production with $T_A = T_J = 25^\circ\text{C}$. All hot and cold limits are guaranteed by correlating the electrical characteristics to process and temperature variations and applying statistical process control.

Note 4: The V_{CC} output is intended as a self bias for the internal gate drive power and control circuits. Device thermal limitations limit external loading.

Note 5: The human body model is a 100pF capacitor discharge through a 1.5k Ω resistor into each pin. The human body ESD compliance level for Pin 7 and 8 is 1000V.

Note 6: For devices procured in the LLP-8 package the $R_{ds(on)}$ limits are guaranteed by design characterization data only.

Typical Performance Characteristics

Operational Waveforms

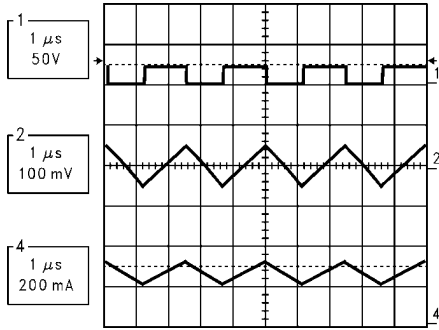

20165508

LM25007 Operation: $V_{OUT} = 10V$, $V_{IN} = 20V$, $I_{OUT} = 250mA$
CH1: Switch Node, CH2: V_{OUT} (AC), CH4: Inductor Current

Operational Waveforms

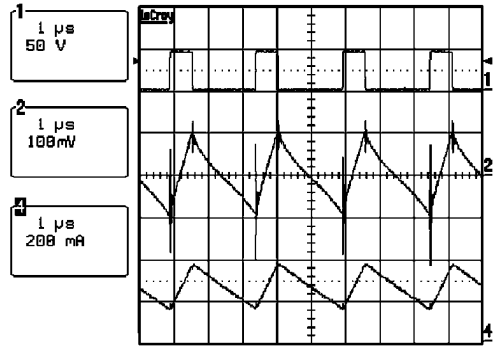

20165509

LM25007 Operation: $V_{OUT} = 10V$, $V_{IN} = 42V$, $I_{OUT} = 250mA$
CH1: Switch Node, CH2: V_{OUT} (AC), CH4: Inductor Current

LM25007 10V Output Efficiency

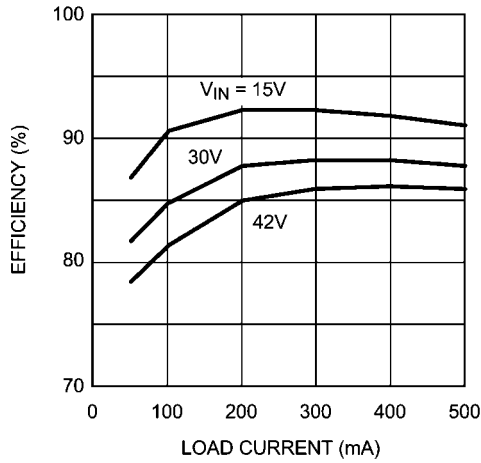

20165510

Current Limit Off-Time vs V_{FB}

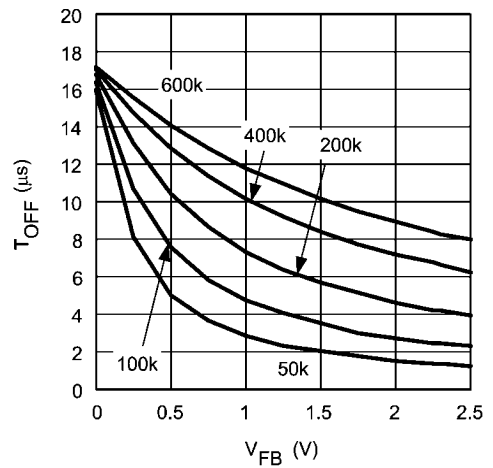

20165511

V_{IN} vs T_{ON}
 $R_{ON} = 100k, 200k, 300k$

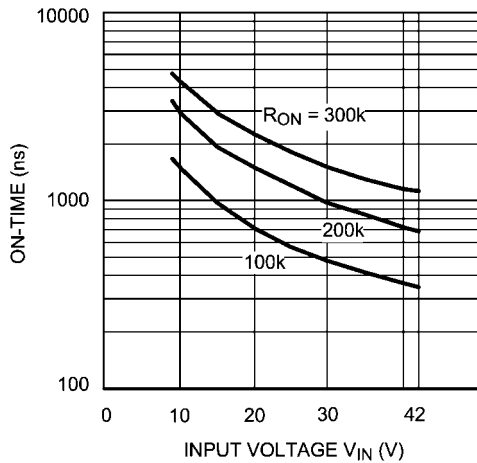

20165512

Detailed Operating Description

The LM25007 is a monolithic step-down switching regulator featuring all of the functions needed to implement low cost, efficient, power supply. Capable of driving a 0.5Amp load over a 9-42V input voltage range, this device is easy to apply and is provided in the small MSOP-8 and the thermally enhanced LLP-8 packages. Ultra-fast transient response is achieved through the use of a constant on-time architecture with V_{in} feed forward. This feature provides an almost constant operating frequency over load and input voltage variations. The operating frequency may be adjusted up to 800kHz depending on input and output voltages. This architecture is easy to use and tolerant of component selection. An intelligent current limit is implemented in the LM25007 with forced off time that is inversely proportional to V_{out} to ensure recovery from fault conditions. The output voltage may be set from 2.5V to >30V. To improve efficiency in light load applications, the V_{cc} pin can be tied to an external voltage source thus eliminating the drop through the integrated internal regulator. Additional protection features include: thermal shutdown, V_{cc} under-voltage lockout, gate drive under-voltage lockout, and max duty cycle limiter.

Hysteretic Control Circuit Overview

The LM25007 is a Buck DC-DC regulator that uses a constant on-time control scheme. The on-time is programmed by an external resistor and varies inversely with line input voltage (V_{in}). The core regulation elements of the LM25007 are the feedback comparator and the on-time one-shot. The regulator output voltage is sensed at the feedback pin (FB) and is compared to an internal reference voltage (2.5V). If the FB signal is below the reference voltage, the buck switch is turned on for a fixed time pulse determined by the line voltage and a programming resistor (R_{ON}). Following the on period the switch will remain off for at least the minimum off timer period of 300ns. If the FB pin voltage is still below the reference after the 300ns off-time, the switch will turn on again for another on time period. This switching behavior will continue until the FB pin voltage reaches the reference voltage level.

The LM25007 operates in discontinuous conduction mode at light load currents or continuous conduction mode at heavier load currents. In discontinuous conduction mode, current through the output inductor starts at zero and ramps up to a peak value during the buck switch on-time and then back to zero during the off-time. The inductor current remains at zero until the next on-time period starts when FB falls below the internal reference. In discontinuous mode the operating frequency is relatively low and will vary with load. Therefore at light loads the conversion efficiency is maintained, since the switching losses decrease with the reduction in load current and switching frequency. The approximate discontinuous mode operating frequency can be calculated as follows:

$$F = \frac{V_{OUT}^2 \times L}{1 \times 10^{-20} \times R_{Load} \times (R_{ON})^2}$$

In continuous conduction mode, current flows continuously through the inductor and never ramps down to zero. In this mode the operating frequency is greater than the discontinuous mode frequency and remains relatively constant with load and line variations. The approximate continuous mode operating frequency can be calculated as follows:

$$F = \frac{V_{OUT}}{1.42 \times 10^{-10} \times R_{ON}}$$

The output voltage (V_{out}) can be programmed by two external resistors as shown in *Figure 1*. The regulated voltage is calculated as follows:

$$V_{OUT} = 2.5 \times (R3 + R4) / R4$$

The feedback comparator in hysteretic regulators depends on the output ripple voltage to switch the output transistor on and off at regular intervals. In order for the internal comparator to respond quickly to changes in output voltage, proportional to inductor current, a minimum amount of capacitor Equivalent Series Resistance (ESR) is required. A ripple voltage of 25mV is recommended at the feedback pin (FB) for stable operation. In cases where the intrinsic capacitor ESR is too small, additional series resistance may be added.

For applications where lower output voltage ripple is required the load can be connected directly to the low ESR output capacitor, as shown in *Figure 1*. The series resistor ($R5$) will degrade the load regulation. Another technique for enhancing the ripple voltage at the FB pin is to place a capacitor in parallel with the feedback divider resistor $R3$. The addition of the capacitor reduces the attenuation of the ripple voltage from the feedback divider.

High Voltage Bias Regulator (VCC)

The LM25007 contains an internal high voltage bias regulator. The input pin (V_{in}) can be connected directly to line voltages from 9 to 42 Volts. To avoid supply voltage transients due to long lead inductances on the input pin (V_{IN}), it is always recommended to connect a low ESR ceramic chip capacitor ($\approx 0.1\mu F$) between V_{IN} and RTN pins located close to the LM25007. The regulator is internally current limited to 11mA. Upon power up, the regulator is enabled and sources current into an external capacitor connected to the V_{CC} pin. When the voltage on the V_{CC} pin reaches its UVLO level (6.3V), the controller output is enabled.

An external auxiliary supply voltage can be diode connected to the V_{cc} pin. If the auxiliary voltage is greater than 7 Volts the internal regulator will shutoff, thus reducing internal power dissipation. Do not exceed 14V at V_{CC} . See *Figure 2*.

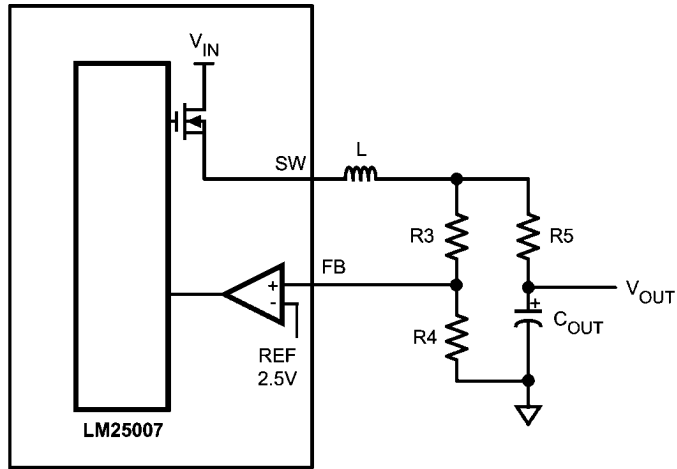

20165505

FIGURE 1. Low Ripple Output Configuration

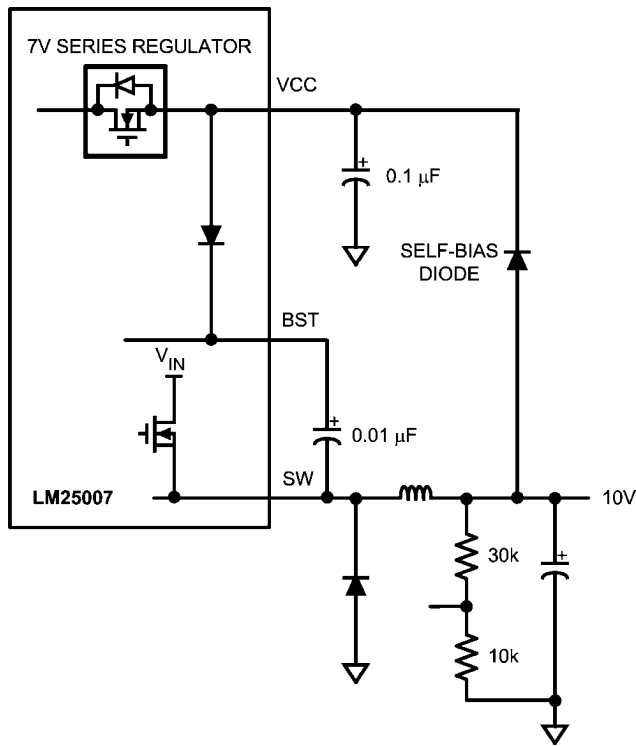

20165506

FIGURE 2. Self Biased Configuration

Over-Voltage Comparator

The over-voltage comparator is provided to protect the output from overvoltage conditions due to sudden input line voltage changes or output loading changes. The over-voltage comparator monitors the FB pin versus an internal 2.875V reference. If the voltage at FB rises above 2.875V the comparator immediately terminates the buck switch on-time pulse.

ON Time generator and Shutdown

The on-time of the LM25007 is set inversely proportional to the input voltage by an external resistor connected between RON/SD and VIN. The RON/SD terminal is a low impedance input biased at approximately 1.5V. The current through the resistor and into the RON/SD pin is approximately propor-

tional to V_{IN} and used internally to control the on-timer. This scheme of input voltage feed-forward hysteretic operation achieves nearly constant operational frequency over varying line and load conditions. The on-time equation for the LM25007 is :

$$T_{on} = 1.42 \times 10^{-10} \times R_{ON} / V_{IN}$$

The RON/SD pin of the LM25007 also provides a shutdown function which disables the regulator and significantly decreases quiescent power dissipation. By pulling the pin below 0.7V activates the low power shutdown mode. The V_{IN} quiescent current in the shutdown mode is approximately 100 μ A internal to the LM25007 plus the current in the R_{ON} resistor. See *Figure 3*

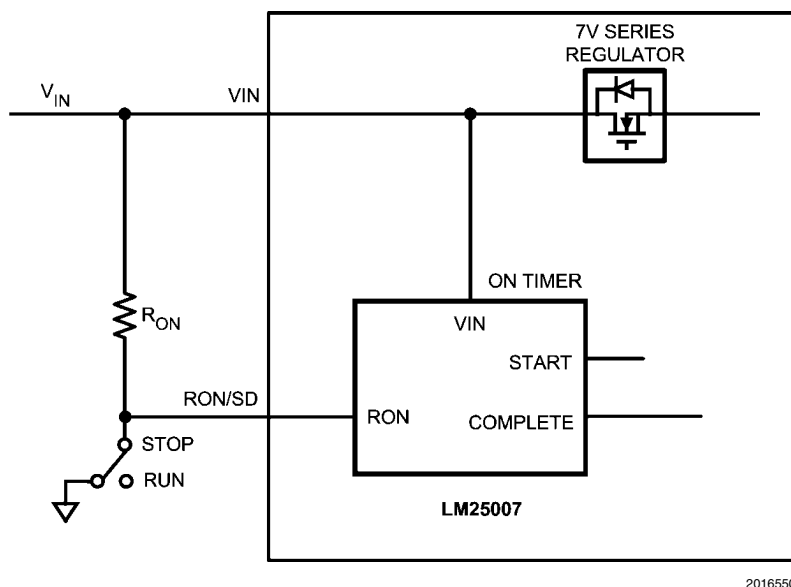

FIGURE 3. Shutdown Implementation

Current Limit

The LM25007 contains an intelligent current limit off-timer intended to reduce the foldback characteristic inherent with fixed off-time over-current protection. If the current in the Buck switch exceeds 725mA the present cycle on-time is immediately terminated (cycle by cycle current limit). Following the termination of the cycle a non-resettable current limit off timer is initiated. The duration of the off time is a function of the external resistor (RCL) and the FB pin voltage. When the FB pin voltage equals zero, the current limit off-time is internally preset to 17 μ s. This condition occurs in short circuit operation when a maximum amount of off-time is required.

In cases of overload (not complete short circuit) the current limit off-time is reduced as a function of the output voltage (measured at the FB pin). Reducing the off-time with smaller overloads reduces the amount of foldback and also reduces the initial start-up time. The current limit off time for a given FB pin voltage and R_{CL} resistor can be calculated by the following equation:

$$T_{off} = 10^{-5} / (0.59 + (V_{FB} / 7.22 \times 10^{-6} \times R_{CL}))$$

Applications utilizing low resistance inductors and/or a low voltage drop rectifier may require special evaluation at high line, short circuit conditions. In this special case the preset

17 μ s (FB = 0V) off-time may be insufficient to balance the inductor volt*time product. Additional inductor resistance, output resistance or a larger voltage drop rectifier may be necessary to balance the inductor cycle volt*time product and limit the short circuit current.

N - Channel Buck Switch and Driver

The LM25007 integrates an N-Channel Buck switch and associated floating high voltage gate driver. The gate driver circuit works in conjunction with an external bootstrap capacitor and an internal high voltage diode. The bootstrap capacitor is charged by V_{CC} through the internal high voltage diode. A 0.01 μ F ceramic capacitor connected between the BST pin and SW pin is recommended.

During each cycle when the Buck switch turns off, the SW pin is approximately 0V. When the SW pin voltage is low, the bootstrap capacitor is charged from V_{CC} through the internal diode. The minimum off timer, set to 300ns, ensures that there will be a minimum interval every cycle to recharge the bootstrap capacitor.

An external re-circulating diode from the SW pin to ground is necessary to carry the inductor current after the internal Buck switch turns off. This external diode must be of the Ultra-fast or Schottky type to reduce turn-on losses and current over-

shoot. The reverse voltage rating of the re-circulating diode must be greater than the maximum line input voltage.

Thermal Protection

Internal Thermal Shutdown circuitry is provided to protect the integrated circuit in the event the maximum junction temperature is exceeded. When thermal protection is activated, typically at 165 degrees Celsius, the controller is forced into a low power reset state, disabling the output driver. This feature is provided to prevent catastrophic failures from accidental device overheating.

Minimum Load Current

A minimum load current of 1 mA is required to maintain proper operation. If the load current falls below that level, the bootstrap capacitor may discharge during the long off-time, and the circuit will either shutdown, or cycle on and off at a low frequency. If the load current is expected to drop below 1 mA in the application, the feedback resistors should be chosen low enough in value so they provide the minimum required current at nominal V_{out} .

10V, 400mA Demo Board Bill of Materials (See Typical Application Circuit)

ITEM	PART NUMBER	DESCRIPTION	VALUE
C1	C4532X7R2A105M	CAPACITOR, CER, TDK	1 μ , 100V
C2	C4532X7R1E156M	CAPACITOR, CER, TDK	15 μ , 25V
C3	C1206C104K5RAC	CAPACITOR, CER, KEMET	0.1 μ , 50V
C4	C1206C103K5RAC	CAPACITOR, CER, KEMET	0.01 μ , 50V
C5	C3216X7R2A104KT	CAPACITOR, CER, TDK	0.1 μ , 100V
D1	MURA110T3	DIODE, 100V, ON SEMI	
L1	SLF7045T-101MR60-1	BUCK INDUCTOR, TDK	100 μ H
R1	CRCW12062003F	RESISTOR	200K
R2	CRCW12061003F	RESISTOR	100K
R3	CRCW12063011F	RESISTOR	3.01K
R4	CRCW12061001F	RESISTOR	1K
R5	CRCW12061R00F	RESISTOR	1
U1	LM25007	REGULATOR, NATIONAL	

Physical Dimensions inches (millimeters) unless otherwise noted

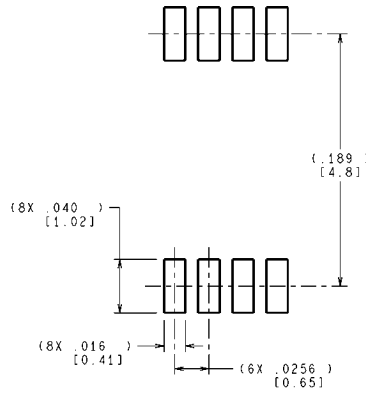
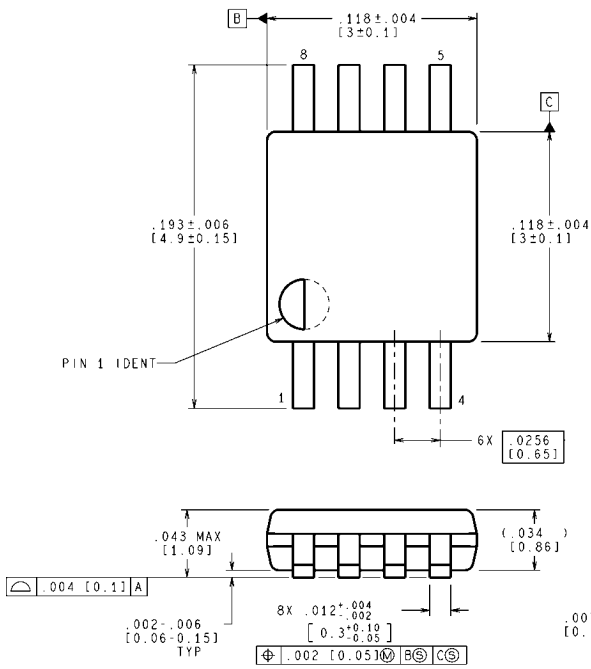

LAND PATTERN RECOMMENDATION

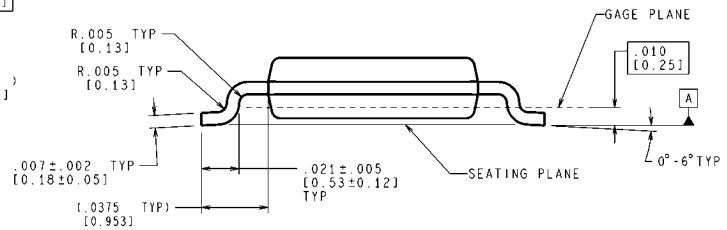

CONTROLLING DIMENSION IS INCH
VALUES IN [] ARE MILLIMETERS

MUA08A (Rev E)

**8-Lead MSOP Package
NS Package Number MUA08A**

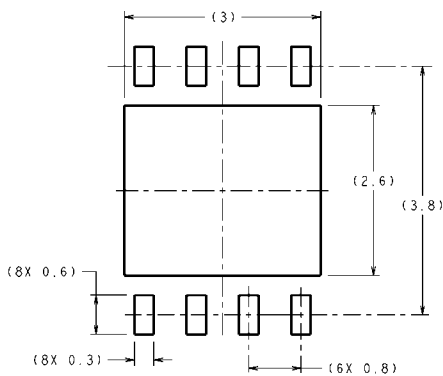

RECOMMENDED LAND PATTERN

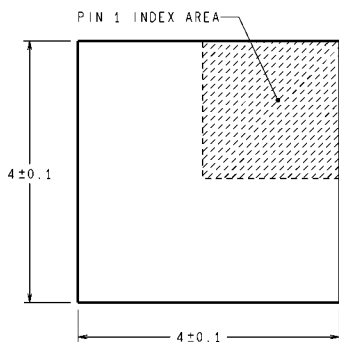

DIMENSIONS ARE IN MILLIMETERS
DIMENSIONS IN () FOR REFERENCE ONLY

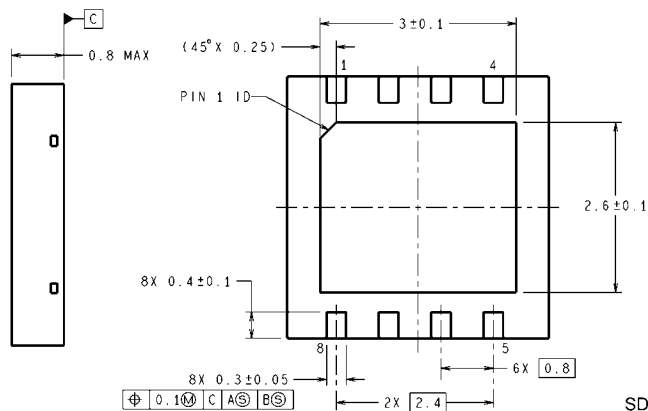
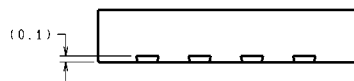

**8-Lead LLP Package
NS Package Number SDC08A**

SDC08A (Rev A)

For more National Semiconductor product information and proven design tools, visit the following Web sites at:

Products		Design Support	
Amplifiers	www.national.com/amplifiers	WEBENCH	www.national.com/webench
Audio	www.national.com/audio	Analog University	www.national.com/AU
Clock Conditioners	www.national.com/timing	App Notes	www.national.com/appnotes
Data Converters	www.national.com/adc	Distributors	www.national.com/contacts
Displays	www.national.com/displays	Green Compliance	www.national.com/quality/green
Ethernet	www.national.com/ethernet	Packaging	www.national.com/packaging
Interface	www.national.com/interface	Quality and Reliability	www.national.com/quality
LVDS	www.national.com/lvds	Reference Designs	www.national.com/refdesigns
Power Management	www.national.com/power	Feedback	www.national.com/feedback
Switching Regulators	www.national.com/switchers		
LDOs	www.national.com/lido		
LED Lighting	www.national.com/led		
PowerWise	www.national.com/powerwise		
Serial Digital Interface (SDI)	www.national.com/sdi		
Temperature Sensors	www.national.com/tempsensors		
Wireless (PLL/VCO)	www.national.com/wireless		

THE CONTENTS OF THIS DOCUMENT ARE PROVIDED IN CONNECTION WITH NATIONAL SEMICONDUCTOR CORPORATION ("NATIONAL") PRODUCTS. NATIONAL MAKES NO REPRESENTATIONS OR WARRANTIES WITH RESPECT TO THE ACCURACY OR COMPLETENESS OF THE CONTENTS OF THIS PUBLICATION AND RESERVES THE RIGHT TO MAKE CHANGES TO SPECIFICATIONS AND PRODUCT DESCRIPTIONS AT ANY TIME WITHOUT NOTICE. NO LICENSE, WHETHER EXPRESS, IMPLIED, ARISING BY ESTOPPEL OR OTHERWISE, TO ANY INTELLECTUAL PROPERTY RIGHTS IS GRANTED BY THIS DOCUMENT.

TESTING AND OTHER QUALITY CONTROLS ARE USED TO THE EXTENT NATIONAL DEEMS NECESSARY TO SUPPORT NATIONAL'S PRODUCT WARRANTY. EXCEPT WHERE MANDATED BY GOVERNMENT REQUIREMENTS, TESTING OF ALL PARAMETERS OF EACH PRODUCT IS NOT NECESSARILY PERFORMED. NATIONAL ASSUMES NO LIABILITY FOR APPLICATIONS ASSISTANCE OR BUYER PRODUCT DESIGN. BUYERS ARE RESPONSIBLE FOR THEIR PRODUCTS AND APPLICATIONS USING NATIONAL COMPONENTS. PRIOR TO USING OR DISTRIBUTING ANY PRODUCTS THAT INCLUDE NATIONAL COMPONENTS, BUYERS SHOULD PROVIDE ADEQUATE DESIGN, TESTING AND OPERATING SAFEGUARDS.

EXCEPT AS PROVIDED IN NATIONAL'S TERMS AND CONDITIONS OF SALE FOR SUCH PRODUCTS, NATIONAL ASSUMES NO LIABILITY WHATSOEVER, AND NATIONAL DISCLAIMS ANY EXPRESS OR IMPLIED WARRANTY RELATING TO THE SALE AND/OR USE OF NATIONAL PRODUCTS INCLUDING LIABILITY OR WARRANTIES RELATING TO FITNESS FOR A PARTICULAR PURPOSE, MERCHANTABILITY, OR INFRINGEMENT OF ANY PATENT, COPYRIGHT OR OTHER INTELLECTUAL PROPERTY RIGHT.

LIFE SUPPORT POLICY

NATIONAL'S PRODUCTS ARE NOT AUTHORIZED FOR USE AS CRITICAL COMPONENTS IN LIFE SUPPORT DEVICES OR SYSTEMS WITHOUT THE EXPRESS PRIOR WRITTEN APPROVAL OF THE CHIEF EXECUTIVE OFFICER AND GENERAL COUNSEL OF NATIONAL SEMICONDUCTOR CORPORATION. As used herein:

Life support devices or systems are devices which (a) are intended for surgical implant into the body, or (b) support or sustain life and whose failure to perform when properly used in accordance with instructions for use provided in the labeling can be reasonably expected to result in a significant injury to the user. A critical component is any component in a life support device or system whose failure to perform can be reasonably expected to cause the failure of the life support device or system or to affect its safety or effectiveness.

National Semiconductor and the National Semiconductor logo are registered trademarks of National Semiconductor Corporation. All other brand or product names may be trademarks or registered trademarks of their respective holders.

Copyright© 2008 National Semiconductor Corporation

For the most current product information visit us at www.national.com



**National Semiconductor
Americas Technical
Support Center**
Email:
new.feedback@nsc.com
Tel: 1-800-272-9959

**National Semiconductor Europe
Technical Support Center**
Email: europe.support@nsc.com
German Tel: +49 (0) 180 5010 771
English Tel: +44 (0) 870 850 4288

**National Semiconductor Asia
Pacific Technical Support Center**
Email: ap.support@nsc.com

**National Semiconductor Japan
Technical Support Center**
Email: jpn.feedback@nsc.com